

## AMCO® SHELVING

### You'll find amazing strength in our numbers.

Compared to conventional wire shelving, the AMCO II® square-post system uses 27% more metal in our posts...our shelf wire averages 50% greater thickness...our welds are larger and stronger — the design of AMCO II® may be unique, but the commitment to quality is all SPG.



### AMCO II® Shelving

- Unique square post design uses 27% more steel for greater strength and durability than typical round post systems
- Frame is 12-ga. solid steel
- Solid 2-1/8" robotic welds provide more stability than the two spot welds used on round post systems
- Shelf wire averages 50% thicker than other systems providing greater shelf capacity and strength
- Shelves come in 5 widths and 8 lengths
- Shelves up to 48" long support up to 1,000 lbs. (450 kg)
- Shelves are available in wire (standard, extra-wide, slanted and inverted with ledge) — plus heavy-duty, 18-ga. solid stainless steel, and plastic (Plasteel® and Plastic Plus®)
- Assembly is fast and easy with a one-piece shelf installation adapter
- Posts are notched on 2" centers to assure perfect shelf alignment every time
- Shelves have solid edges instead of truss edges, making them easier to clean and label

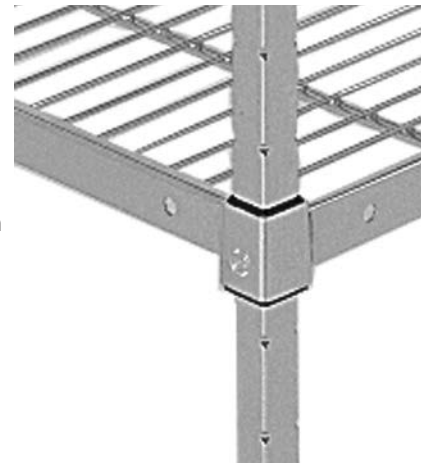

### AMCO II® Starter Unit Kits

- Kits come with 4 posts and 4 or 5 shelves.
- Kits are available in 18" and 24" widths, and 64", 72" and 84" heights
- Select finish and add appropriate suffix to model number (see chart)

Finish	Use Suffix
Plating Plus™	CP
Polygard® (Blue)	PG
Stainless Steel	SS



#### 4-Tier 72-Inch Tall Starter Kits

Model No.	W x L x H (In)	Weight (Lbs.)
<b>18-in. Wide Shelves</b>		
1298	18 x 36 x 72	64
1300	18 x 48 x 72	80
1302	18 x 60 x 72	92
<b>24-in. Wide Shelves</b>		
1314	24 x 36 x 72	74
1316	24 x 48 x 72	94
1318	24 x 60 x 72	112

#### 5-Tier 84-Inch Tall Starter Kits

Model No.	W x L x H (In)	Weight (Lbs.)
<b>18-in. Wide Shelves</b>		
2458	18 x 36 x 84	66
2460	18 x 48 x 84	86
2462	18 x 60 x 84	101
<b>24-in. Wide Shelves</b>		
1474	24 x 36 x 84	90
1476	24 x 48 x 84	115
1478	24 x 60 x 84	137

## AMCO II® Posts

Model No.	Height (In)	Height (mm)	Weight (Lbs.)	Weight (Kg.)
<b>For Stationary Units</b>				
P64	64	1625	4.5	2
P72	72	1830	5	2
P84	84	2130	5.5	2.5
<b>For use with stem casters*</b>				
PC64	64	1220	4.5	2
PC72	72	1370	5	2
PC84	84	1525	5.5	2.5

\*Go Mobile - order Stem caster on page 80

## AMCO II® Shelves

Model No.	W x L (In)	W x L (mm)	Weight (Lbs.)	Weight (Kg.)
A1836	18 x 36	455 x 915	11	5
A1848	18 x 48	455 x 1220	15	7
A1860	18 x 60	455 x 1525	18	8
A2436	24 x 36	610 x 915	13.5	6
A2448	24 x 48	610 x 1220	18.5	8
A2460	24 x 60	610 x 1525	23	10

## Essentials By AMCO® Kits

- The ideal shelving for lighter load applications (up to 600 lbs. per shelf)
- Assembles easily in minutes
- Starter units consist of 4 shelves and 4 split posts
- Add-On units consist of 4 shelves, 2 split posts and 2 add-on clips for each shelf
- For dry storage only



Starter Unit Model No.	Color	W x L x H (In)	Weight (Lbs.)
B183672GR	Grey	18 x 36 x 72	53
B184872GR	Grey	18 x 48 x 72	60
Add-On Unit Model No.	Color	W x L x H (In)	Weight (Lbs.)
BA183672GR	Grey	18 x 36 x 72	47
BA184872GR	Grey	18 x 48 x 72	54

Additional sizes and customized shelving solutions available — call the factory or your SPG rep for information.



SPG's foodservice products are all manufactured to meet NSF standards. For specific items, visit [www.nsf.org](http://www.nsf.org)

## ISS™ SHELVING

### Our most popular shelving for a lot of excellent reasons.

Versatility, innovation, strength — ISS™ brings it all together in a durable line of wire shelving that is both easy-to-assemble and competitively priced. So it's no wonder you'll find ISS™ shelving and accessories contributing to the efficiency and profitability of so many foodservice operations.



### ISS™ Shelving

- Durable round post system is interchangeable with other manufacturers' shelving products
- Ideal for most any environment
- Shelves up to 60" long are rated to support 1,250 lbs. of uniformly distributed static weight
- Shelves feature extra trusses for a higher load rating, less deflection and the ability to use longer shelves
- Posts are numbered on 1" increments to speed assembly and ensure more precise shelf alignment
- Our one-piece hinged Sure-Lock™ coupler makes assembly easy and improves stability
- The marine waterfall shelf edge allows easy loading and unloading
- Shelves are available in wire (standard, wide-body, and inverted), dunnage, Series 300 solid stainless steel and plastic
- Four finishes are available — plus designer colors



### Starter Unit Convenience Packs

- Convenient 4-shelf unit packed in one carton
- Each carton has 4 shelves and four 2-piece split posts to make one 70" post
- Cartons take up minimal warehouse space
- One carton each saves on shipping costs and tracking time
- Ideal for immediate storage needs
- Available in four sizes and two finishes, Gold Bond® (Y) and Plating Plus (C) add finish suffix to model number

Model No.	W x L x H (in.)	W x L x H (mm)	Weight (Lbs.) (Kg)	
1836PK	18 x 36 x 70	457 x 914 x 1778	49	22
1848PK	18 x 48 x 70	457 x 1219 x 1778	66.5	30
2436PK	24 x 36 x 70	610 x 914 x 1778	62	28
2448PK	24 x 48 x 70	610 x 1219 x 1778	78.5	35

To order, add finish suffix to model number



SPG's foodservice products are all manufactured to meet NSF standards. For specific items, visit [www.nsf.org](http://www.nsf.org)

## ISS™ Wire Shelves

Model No.	W x L (In) (mm)	Weight (Lbs.) (Kg)
<b>14-in. Wide Shelves</b>		
1436	14 x 36 356 x 914	9 4
1448	14 x 48 356 x 1219	11.5 5
1460	14 x 60 356 x 1524	15 7
<b>18-in. Wide Shelves</b>		
1836	18 x 36 457 x 914	11 5
1848	18 x 48 457 x 1219	14 6
1860	18 x 60 457 x 1524	16.5 7.5
<b>24-in. Wide Shelves</b>		
2436	24 x 36 610 x 914	13 6
2448	24 x 48 610 x 1219	17 8
2460	24 x 60 610 x 1524	20.5 10



## ISS™ Posts

Model No.	Height (In) (mm)	Weight (Lbs.) (Kg)
<b>Digital Posts® For Stationary Shelving Units</b>		
P74	75 1899	4 2
P86	87 2203	5 2
<b>Digital Posts® For Use With Stem Casters</b>		
P74N	75 1899	4 2
P86N	87 2203	5 2

Select finish and add appropriate suffix to model number

Finish	Use Suffix
Plating Plus™	C
Grey Bond®	E
Gold Bond®	Y
Stainless Steel	S

Colors (minimum order required)	
Black	ESB
Red	ESR

# SMARTshelf™ SHELVING SYSTEM

## Store Merchandising and Retail trade Shelf System



### STANDARD FEATURES & BENEFITS

- The patented SMARTshelf™ shelving system is easy to assemble - no tools required
- The distance between shelves can be adjusted easily on 1" increments by simply moving the self-aligning support hooks
- Posts will accommodate both adjustable and fixed shelving
- The SMARTshelf™ system has a durable bright plated finish; optional colors available upon request
- Each shelf supports up to 300 lbs.
- Multiple shelf sizes available

Length	Shelves		Posts Height
	Width	Height	
24"	14"	34"	
30"	18"	54"	
36"	21"	62"	
42"	24"	74"	
48"	—	86"	
54"	—	—	
60"	—	—	

# ISS CONTENDER™ SHELVING High-performance. Great value.

With our ISS Contender™ line, SPG has driven down the cost of wire shelving without sacrificing performance. ISS Contender™ offers impressive strength and capacity for general applications, corrosion resistance for all environments, ease of assembly — and just about everything you would expect to find on higher cost shelving.



- ISS Contender™ round post shelving is a strong, economical solution for both dry and refrigerated storage needs
- Available with Plating Plus™ finish for display and dry environments — or Contender Grey™ Epoxy finish which is warranted for seven years against naturally occurring corrosion in high-moisture, high-humidity environments
- Each 48" shelf is rated to support up to 800 lbs. (363 kgs) of uniformly distributed static load weight — longer shelves can support up to 600 lbs. (272 kgs)
- Assembles in minutes without tools or hardware
- Shelves are installed on the posts in 1" (25mm) increments — and can be changed easily as storage needs change



More Information  
on our website  
[www.spgusa.com](http://www.spgusa.com)



## Shelving Kit Convenience Packs

- Four shelves and four 70" split posts
- Available in Plating Plus™ or Contender Grey™ Epoxy finishes

Contender Grey™ Model#	Plating Plus™ Model#	(in.)	(mm.)	(lbs.)	(kg.)
IC183674KITCG	IC183674KITC	18 x 36 x 74	457 x 914 x 1880	54.00	24.50
IC184874KITCG	IC184874KITC	18 x 48 x 74	457 x 1219 x 1880	64.00	29.10
IC186074KITCG	IC186074KITC	18 x 60 x 74	457 x 1524 x 1880	84.00	38.20
IC243674KITCG	IC243674KITC	24 x 36 x 74	610 x 914 x 1880	68.00	30.90
IC244874KITCG	IC244874KITC	24 x 48 x 74	610 x 1219 x 1880	78.00	31.80
IC246074KITCG	IC246074KITC	24 x 60 x 74	610 x 1524 x 1880	92.00	41.80



SPG's foodservice products are all manufactured to meet NSF standards. For specific items, visit [www.nsf.org](http://www.nsf.org)

## ISS Contender™ Wire Shelves

Model No.	W x L (in.) (mm)	Weight (Lbs.) (Kg)
<b>18-in. Wide Shelves</b>		
IC1836	18 x 36 457 x 914	9.5 4
IC1848	18 x 48 457 x 1219	12 5
IC1860	18 x 60 457 x 1524	17 8
<b>24-in. Wide Shelves</b>		
IC2436	24 x 36 610 x 914	13 6
IC2448	24 x 48 610 x 1219	16 7
IC2460	24 x 60 610 x 1524	21 9.5

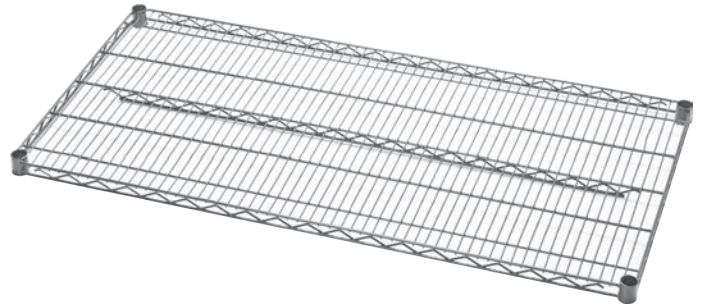

Add finish suffix to model number  
 ISS Contender™ shelves are available:  
 In 14", 18", 21" and 24" widths  
 In 24", 30", 36", 42", 48", 54", 60" and 72" lengths  
 To order other sizes: use MA + shelf width + shelf length +  
 finish suffix (Example: MA1824C)

## ISS Contender™ Posts For Stationary Use

Model No.	Height (In) (mm)	Weight (Lbs.) (Kg)
IC072	72 1829	4 2
IC084	84 2134	5 2

Add finish suffix to model number  
 ISS Contender™ posts are also available:  
 In 7", 34", 54" and 64" heights



Posts for Stationary Use



Posts for Stem Casters

## ISS Contender™ Posts With No Foot For Use With Stem Casters

Model No.	Height (In) (mm)	Weight (Lbs.) (Kg)
IC064NF	64 1626	3.5 2
IC072NF	72 1829	4 2
IC084NF	84 2134	5 2

Add finish suffix to model number  
 ISS Contender™ posts are also available:  
 In 7", 34", 54" and 64" heights

Finish	Use Suffix
<b>Plating Plus™</b> finish for display and dry environment applications — 1-Year Warranty against corrosion in dry environments	C
<b>Contender Grey™</b> finish for moist/humid environments — 7-Year Warranty under normal use against naturally occurring corrosion	CG



## ISS™ NEW ERA™ SHELVING

The same type of quality, durability and performance you'll find in our popular ISS™ wire shelving in a plastic solution — it's one more choice SPG offers, and one more reason to choose SPG as your single source for storage solutions.



- Corrosion free shelves — heavy-duty epoxy coated steel frames and grey polypropylene plastic removable panels
- Antimicrobial agent protects the shelf finishes from bacteria, mold, mildew and fungi that cause odors, stains and product degeneration — keeping shelving cleaner in between cleanings\*
- Available in solid and vented styles
- Sectional panels are easy to remove and clean
- Shelves can be used with ISS™ posts and shelving components — stainless steel posts recommended
- No tools or hardware required
- Can be used in all environments from -20°F (-29°C) to 190°F (88°C)
- Load capacity of 1,000 lbs. (455kgs) per shelf of uniformly distributed static weight

\* This product does not protect users or others against bacteria, viruses, germs or other disease organisms. It is for the protection of the product only. The antimicrobial product should always be thoroughly cleaned after each use.



SPG's foodservice products are all manufactured to meet NSF standards. For specific items, visit [www.nsf.org](http://www.nsf.org)



## New Era™ Vented Shelves

Model No.	W x L (in.)	(mm)	Weight (Lbs.) (Kg)	
<b>18-in. Wide Shelves</b>				
LPS1836V	18 x 36	457 x 914	12	5
LPS1848V	18 x 48	457 x 1219	15.5	7
LPS1860V	18 x 60	457 x 1524	19.5	9
<b>24-in. Wide Shelves</b>				
LPS2436V	24 x 36	610 x 914	14	6
LPS2448V	24 x 48	610 x 1219	18	8
LPS2460V	24 x 60	610 x 1524	23	10

New Era™ Shelves are available:  
 In 18", 21" and 24" widths  
 In 24", 30", 36", 42", 48", 54" and 60" lengths



## New Era™ Solid Shelves

Model No.	W x L (in.)	(mm)	Weight (Lbs.) (Kg)	
<b>18-in. Wide Shelves</b>				
LPS1836S	18 x 36	457 x 914	12	5
LPS1848S	18 x 48	457 x 1219	15.5	7
LPS1860S	18 x 60	457 x 1524	19.5	9
<b>24-in. Wide Shelves</b>				
LPS2436S	24 x 36	610 x 914	14	6
LPS2448S	24 x 48	610 x 1219	18	8
LPS2460S	24 x 60	610 x 1524	23	10

New Era™ Shelves are available:  
 In 18", 21" and 24" widths  
 In 24", 30", 36", 42", 48", 54" and 60" lengths

## New Era™ Posts

Model No. Stationary Posts	Model No. Mobile Posts	Height (in.)	Height (mm)	Weight (Lbs.)	Weight (Kg)
<b>Stainless Steel Posts</b>					
P74S	P74NS	75	1899	4	2
P86S	P86NS	87	2203	5	2
<b>Steel Posts With Grey Bond® Finish</b>					
P74E	P74NE	75	1899	4	2
P86E	P86NE	87	2203	5	2

Stainless Steel and Grey Bond® are the optimum finishes for use with New Era™ Shelves

New Era™ Posts are also available in:  
 8", 14", 34", 54" and 62" heights



# PLASTIC SHELVING

## AMCO® PLASTIC PLUS® & PLASTEEL® SHELVING

Two great options, one reliable source.

AMCO® Plastic Plus™ solid polypropylene plastic removable panels or Plasteel® steel-reinforced plastic shelves — both offer durable performance in any environment, are compatible with AMCO® accessories and deliver the quality and value that you expect from SPG.



### AMCO® Plastic Plus® Shelving

- Grey polypropylene plastic removable panels easily snap onto heavy duty epoxy coated frames
- Sectional panels can be easily removed from frames for cleaning — no tools or hardware required
- An antimicrobial agent protects the finish from bacteria, mold, mildew and fungi that cause odors, stains and product degradation\*
- For all environments from -20°F (-29°C) to 190°F (88°C)
- Strength rated to support 1,000 lbs. (455kg) of uniformly loaded static weight per shelf
- Fits standard AMCO® square posts and is compatible with other AMCO® shelving products
- Stainless steel posts recommended for a rust-free solution

\* This product does not protect users or others against bacteria, viruses, germs or other disease organisms. It is for the protection of the product only. This antimicrobial product should always be thoroughly cleaned after each use.



### AMCO® Plastic Plus® Vented Shelves

Model No.	W x L (in.)	(mm)	Weight (Lbs.) (Kg)	
<b>18-in. Wide Shelves</b>				
PP1836V	17 x 36	455 x 915	12	5
PP1848V	17 x 48	455 x 1220	15.5	7
PP1860V	17 x 60	455 x 1525	19.5	9
<b>24-in. Wide Shelves</b>				
PP2436V	23 x 36	610 x 915	14	6
PP2448V	23 x 48	610 x 1220	18	8
PP2460V	23 x 60	610 x 1525	23	10



Plastic Plus® shelves are available:

In 18" and 24" widths

In 24", 30", 36", 42", 48", 54" and 60" lengths

## Plastic Plus® Solid Shelves

Model No.	W x L (in.)	(mm)	Weight (Lbs.)	(Kg)
<b>18-in. Wide Shelves</b>				
PP1836S	17 x 36	455 x 915	12	5
PP1848S	17 x 48	455 x 1220	15.5	7
PP1860S	17 x 60	455 x 1525	19.5	9
<b>24-in. Wide Shelves</b>				
PP2436S	23 x 36	610 x 915	14	6
PP2448S	23 x 48	610 x 1220	18	8
PP2460S	23 x 60	610 x 1525	23	10



Plastic Plus® shelves are available:

In 18" and 24" widths

In 24", 30", 36", 42", 48", 54" and 60" lengths

## AMCO II® Plasteel® Shelves

- Steel-reinforced plastic shelves support 1,000 lbs. each
- Available in solid or vented style — solid style has raised edge to contain liquid spills
- Grey high-impact structural foam plastic
- May be used with all other styles of Amco II® shelves
- Solid style accepted by the United States Department of Agriculture for direct food contact
- Stainless steel post recommended since it never rusts

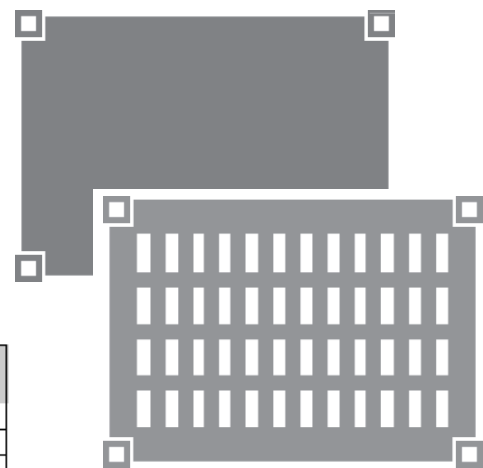

Vented Shelf Model No.	Solid Shelf Model No.	W x L (in.)	(mm)	Weight (Lbs.)	(Kg)
PS1836V	PS1836S	17 x 36.5	476 x 927	16	7
PS1842V	PS1842S	17 x 42.5	476 x 1080	17	8
PS1848V	PS1848S	17 x 48.5	476 x 1232	21	9.5
PS1860V	PS1860S	17 x 60.5	476 x 1537	29	13
PS2436V	PS2436S	25 x 36.5	629 x 927	19	9
PS2442V	PS2442S	25 x 42.5	629 x 1080	21	9.5
PS2448V	PS2448S	25 x 48.5	629 x 1232	25	11
PS2460V	PS2460S	25 x 60.5	629 x 1537	33	15

## AMCO® Posts For Plastic Plus® and Plasteel® Shelving

Model No.	Height (in.)	(mm)	Weight (Lbs.)	(Kg)
<b>Stationary Stainless Steel Posts</b>				
P72SS	72	1830	5	2
P84SS	84	2130	5.5	2.5
<b>Stationary Steel Posts With Grey Bond® Finish</b>				
P72GR	72	1830	5	2
P84GR	84	2130	5.5	2.5
<b>Mobile Stainless Steel Posts</b>				
PC72SS	72	1830	5	2
PC84SS	84	2130	5.5	2.5
<b>Mobile Steel Posts With Grey Bond® Finish</b>				
PC72GR	72	1830	5	2
PC84GR	84	2130	5.5	2.5



- 16-ga. (.065") 1" O.D. square tube construction
- Notched every 2" on each corner
- Includes a top polypropylene post cap
- Stationary posts have a nylon housing on the bottom for a steel leveler



SPG's foodservice products are all manufactured to meet NSF standards. For specific items, visit [www.nsf.org](http://www.nsf.org)

AMCO® posts are available in:

8", 14", 34", 54", 64", 72" and 84" heights

Stainless steel (SS), Grey Bond® (GR) or Polygard® (PG) finishes

## KELMAX SHELVING

All the advantages of aluminum,  
all the quality of SPG.

Synonymous with quality aluminum products, our Kelmax line offers a wide range of choices that are rustproof, lightweight, support up to 1,500 lbs. per shelf and excel in any environment and in any application.



- Aluminum construction offers higher load ratings — so larger loads can be supported across a longer span of shelving
- Aluminum shelving is ideal in hot or caustic applications that might damage the coating of wire shelving
- Kelmax shelving is warranted to be free from manufacturing defects for five years

### Kelmax Fixed Shelving Units

- All welded aluminum shelving ships set up
- Overall height is 60" for 2 and 3-shelf units and 72" for 4-shelf unit
- Mitered top for extra strength
- Clearance between shelves:  
Two-shelf unit: 48.5"  
Three-shelf unit: 22.5"  
Four-shelf unit: 18.5"
- Choose from 4 types of shelves



SPG's foodservice products are all manufactured to meet NSF standards. For specific items, visit [www.nsf.org](http://www.nsf.org)



### Kelmax 4-Tier Shelving Units

Tubular Shelf Model No.	T-Bar Shelf Model No.	Channel Shelf Model No.	Solid Shelf Model No.	L x W x H (in.)	L x W x H (mm)	Weight (Lbs.) (Kg)	
<b>20- in. Wide Shelves</b>							
4H0571	4H4083	4H2414	4H6898	36 x 20 x 72	914 x 508 x 1829	48	22
4H0594	4H4082	4H0490	4H6900	48 x 20 x 72	1219 x 508 x 1829	59	27
4H0610	4H0646	4H0525	4H6902	60 x 20 x 72	1524 x 508 x 1829	70	32
<b>24- in. Wide Shelves</b>							
4H0578	4H0641	4H0468	4H6899	36 x 24 x 72	914 x 610 x 1829	54	24
4H0602	4H0645	4H0506	4H6901	48 x 24 x 72	1219 x 610 x 1829	66	30
4H0618	4H0649	4H0540	4H6541	60 x 24 x 72	1524 x 610 x 1829	79	36

Also available in 2-tier and 3 tier units

## Kelmax Aluminum Adjustable Shelving

- Create a custom aluminum shelving solution with a choice of four different shelving types (see below)
- Load capacities from 900 lbs. to 2,100 lbs. per shelf
- Shelves are adjustable and interchangeable in the same width and length

Solid Shelf Model No.	Tubular Shelf Model No.	T-Bar Shelf Model No.	Channel Shelf Model No.	(in.)	L x W (mm)	Weight (Lbs.) (Kg)	
<b>18-in. Wide Shelves</b>							
4H0208	4H0177	4H0246	4H0082	36 x 18	914 x 457	8	4
4H0210	4H0179	4H0248	4H0084	48 x 18	1219 x 457	11	5
4H0212	4H0181	4H0250	4H0086	60 x 18	1524 x 457	13	6
<b>24-in. Wide Shelves</b>							
4H0226	4H0191	4H0260	4H0097	36 x 24	914 x 610	9	4
4H0228	4H0193	4H0262	4H0099	48 x 24	1219 x 610	13	6
4H0230	4H0195	4H0264	4H0102	60 x 24	1524 x 610	15	7

Also available in 20" and 30" shelf widths

### Shelf Selection Guide

Which shelves are right for you? Use this quick reference to help guide your selection:

**Solid Shelves:** A solid all-around choice — ideal for storage of small items and to contain spills.

**Tubular Shelves:** Ideal for the storage of cases or large boxes.

**T-Bar Shelves:** The extra vertical support you need when storing items perpendicularly.

**Channel Shelves:** Provide extra strength for large or small items, while allowing air circulation.



Solid Shelf



Tubular Shelf

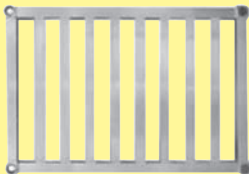

T-Bar Shelf



Channel Shelf



### Kelmax Posts

Model No.	Height (in.)	Height (mm)	Weight (Lbs.)	Weight (Kg)
4H0162	76	1930	4	2
4H0167	84	2134	5	2.5

## Freestyle® CANTILEVER SHELVING — the ultimate in freestanding cooler/freezer storage.

In real-store tests, Freestyle® shelving systems increased usable storage surface space up to 68% in coolers and up to 60% in freezers — which makes Freestyle® a proven way to get more out of every square foot of your operation and every dollar of your shelving investment.



- Each shelf has a load-bearing capacity of 600 lbs. with a unit rating of 1,800 lbs. for cantilevered shelves and 1,000 lbs. capacity on the bottom shelf — for a total unit capacity of 2,800 lbs.
- No front uprights — so it offers greater accessibility to inventory
- Increases sq. ft. and cubic volume storage capacity in existing footprint
- Adjustable shelves on 2" increments for maximum flexibility — no tools required
- Unit is fully expandable side-to-side with Add-On unit — using common uprights with dual-side adjustment
- Durable heavy-duty steel construction
- Shelving available in 5 widths and 8 lengths
- Uprights available in 5 heights
- Shelves, uprights, and frame kits have a durable grey epoxy-based finish with advanced antimicrobial protective agent
- Complete assortment of accessories including hanger rails and shelf covers in wire and stainless steel



SPG's foodservice products are all manufactured to meet NSF standards. For specific items, visit [www.nsf.org](http://www.nsf.org)

See it in action!

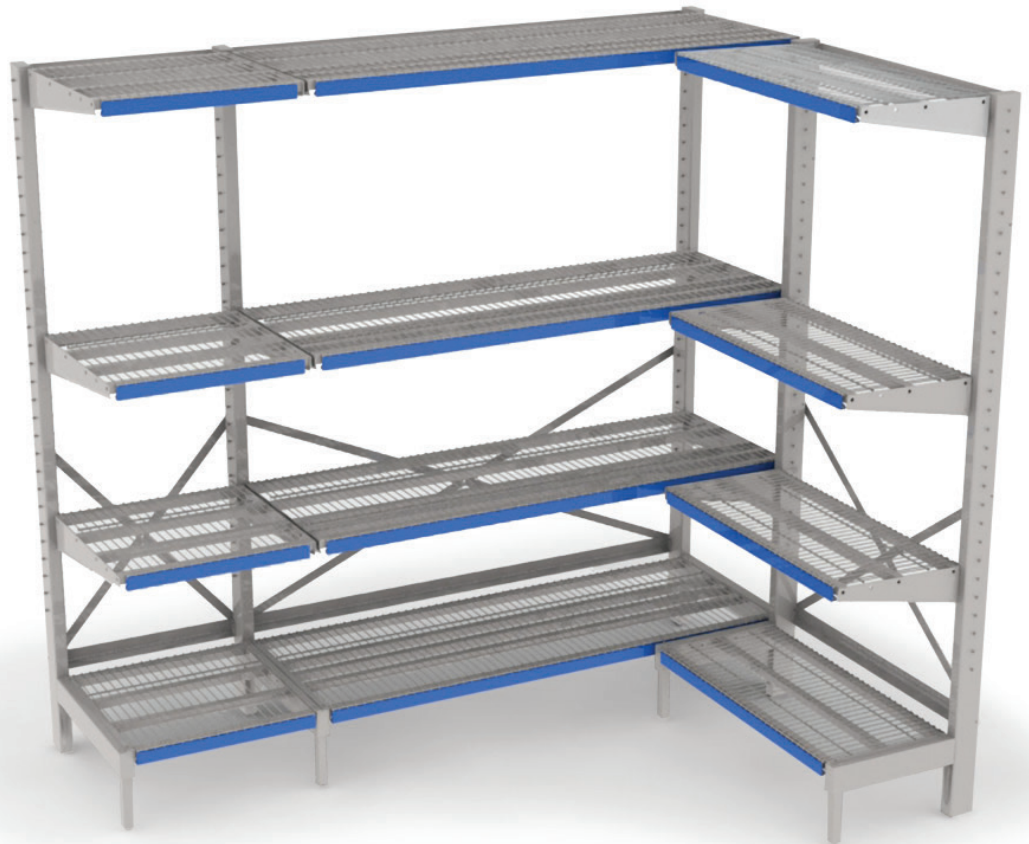

## Freestyle® 4-Tier Starter Units

Includes: 1 starter frame kit, 3 standard shelves, 1 bottom shelf.  
4 standard wire covers with label holders.

Model No.	W x L x H		Weight	
	(in.)	(mm)	(Lbs.)	(Kg)
FSMS741836E	18 x 36 x 74	457 x 914 x 1880	138	62
FSMS741848E	18 x 48 x 74	457 x 1219 x 1880	158	72
FSMS741860E	18 x 60 x 74	457 x 1534 x 1880	193	88
FSMS742436E	24 x 36 x 74	609 x 914 x 1880	160	72
FSMS742448E	24 x 36 x 74	609 x 1219 x 1880	185	84
FSMS742460E	24 x 36 x 74	609 x 1534 x 1880	211	96
FSMS861836E	18 x 36 x 86	457 x 914 x 2184	144	66
FSMS861848E	18 x 48 x 86	457 x 1219 x 2184	165	75
FSMS861860E	18 x 60 x 86	457 x 1534 x 2184	200	91
FSMS862436E	24 x 36 x 86	609 x 914 x 2184	166	75
FSMS862448E	24 x 48 x 86	609 x 1219 x 2184	191	87
FSMS862460E	24 x 60 x 86	609 x 1534 x 2184	217	98

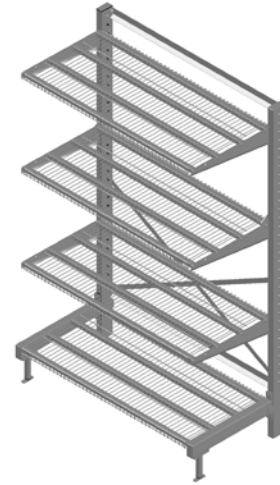

## Freestyle® 4-Tier Add-On Units

Includes: 1 add-on frame kit, 3 standard shelves, 1 bottom shelf.  
4 standard wire covers with label holders.

Model No.	W x L x H		Weight	
	(in.)	(mm)	(Lbs.)	(Kg)
FSMA741836E	18 x 36 x 74	457 x 914 x 1880	111	51
FSMA741848E	18 x 48 x 74	457 x 1219 x 1880	132	60
FSMA741860E	18 x 60 x 74	457 x 1534 x 1880	167	76
FSMA742436E	24 x 36 x 74	609 x 914 x 1880	132	60
FSMA742448E	24 x 48 x 74	609 x 1219 x 1880	158	72
FSMA742460E	24 x 60 x 74	609 x 1534 x 1880	183	83
FSMA861836E	18 x 36 x 86	457 x 914 x 2184	115	52
FSMA861848E	18 x 48 x 86	457 x 1219 x 2184	135	61
FSMA861860E	18 x 60 x 86	457 x 1534 x 2184	170	77
FSMA862436E	24 x 36 x 86	609 x 914 x 2184	136	62
FSMA862448E	24 x 48 x 86	609 x 1219 x 2184	161	73
FSMA862460E	24 x 60 x 86	609 x 1534 x 2184	187	85

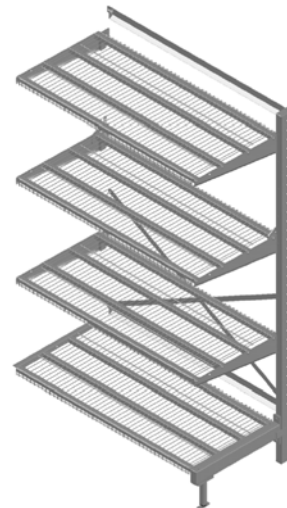

## Freestyle® Reinforcement Brace

- Dramatically increases the load capacity of Freestyle® shelving:
  - by 25% on 30-in. shelves, from 600 lbs. to 800 lbs.
  - by 40% on shelves up to 24-in. deep, from 600 lbs. to 1,000 lbs.
- Provides the additional strength critical for the storage and display of heavy, high-density products
- Low-profile design and placement make it virtually invisible and will not interfere with shelf positioning
- Installation is fast, easy and requires no tools
- Significantly increases the life of your shelving
- Set includes 1 left and 1 right brace for shelf

Model No.	Weight(Lbs.)
FSRBESET	0.5

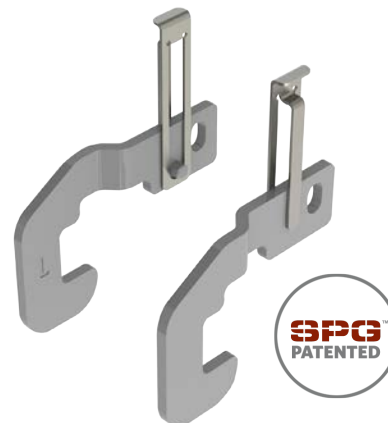

## CANTILEVER SHELVING

# Freestyle® CANTILEVER BEER CAVE SHELVING with SWEEPING CORNER



- The Freestyle sweeping corner bridges the gap between adjacent corner Freestyle units without the use of a shared upright
- Provides easier access for product retrieval and stocking for employees
- Provides greater visibility and accessibility for customers, maximizes profit
- Introduces a new visual aesthetic to beer caves or other consumer products
- Durable heavy-duty powdercoated steel and stainless steel options, in both vented and solid models
- Powder-coated shelves have a durable gray epoxy-based finish with advanced antimicrobial protective agent
- Made to fit standard depth Freestyle shelving, simply sets in place
- Each bridge extends the load bearing surface of the shelves





## QUICK ORDER KITS – 3 & 4 TIER, VENTED & SOLID, COMPLETE CORNER, GREY BOND

	Model No.	Description	Shelf Depth	Includes
<b>- Tier</b>	<b>3 - Tier Solid Grey Bond Corner Kit</b>			
	<b>FSACS24E-3T-KIT</b>	Angled Corner 24" Shelf Kit - 3 Tier; Solid Bridges	24	4 upper bridges; 2 bottom bridges; 4 back braces
	<b>FSACS30E-3T-KIT</b>	Angled Corner 30" Shelf Kit - 3 Tier; Solid Bridges	30	4 upper bridges; 2 bottom bridges; 4 back braces
	<b>3 - Tier Vented Grey Bond Corner Kit</b>			
	<b>FSACV24E-3T-KIT</b>	Angled Corner 24" Shelf Kit - 3 Tier; Vented Bridges	24	4 upper bridges; 2 bottom bridges; 4 back braces
	<b>FSACV30E-3T-KIT</b>	Angled Corner 30" Shelf Kit - 3 Tier; Vented Bridges	30	4 upper bridges; 2 bottom bridges; 4 back braces
<b>- Tier</b>	<b>4 - Tier Solid Grey Bond Corner Kit</b>			
	<b>FSACS24E-4T-KIT</b>	Angled Corner 24" Shelf Kit - 4 Tier; Solid Bridges	24	6 upper bridges; 2 bottom bridges; 4 back braces
	<b>FSACS30E-4T-KIT</b>	Angled Corner 30" Shelf Kit - 4 Tier; Solid Bridges	30	6 upper bridges; 2 bottom bridges; 4 back braces
	<b>4 - Tier Vented Grey Bond Corner Kit</b>			
	<b>FSACV24E-4T-KIT</b>	Angled Corner 24" Shelf Kit - 4 Tier; Vented Bridges	24	6 upper bridges; 2 bottom bridges; 4 back braces
	<b>FSACV30E-4T-KIT</b>	Angled Corner 30" Shelf Kit - 4 Tier; Vented Bridges	30	6 upper bridges; 2 bottom bridges; 4 back braces

## SWEEPING CORNER BRACING KITS

4 braces for a 2-sided configuration

Model No.	Shelf Depth	Qty
FSACAS18*KIT4	18	4
FSACAS24*KIT4	24	4
FSACAS30*KIT4	30	4

## AVAILABLE FINISHES

Finish	Suffix
Grey Bond	E

## AMCO® MOD-A-FLEX® SHELVING Get more out of your coolers & freezers

This unique, patented shelving system is supported from the walls or ceiling, eliminating front posts and increasing storage capacity by 30%. The Mod-A-Flex® system also features an impressive 400-lb. per shelf capacity, an antimicrobial grey-epoxy finish and all the features you need to store more and earn more.



Every detail of the Mod-A-Flex® system is designed to improve employee efficiency, productivity and speed of service — reducing labor and storage costs while contributing to overall operational results.

Mod-A-Flex® not only increases storage capacity up to 30% ... it also offers greater organization and higher visibility of stock... shelves can also be quickly and easily removed and repositioned...and because there are no posts, cleaning the floor is faster, easier and more thorough.

### Mod-A-Flex® System

- Designed for walk-in coolers and freezers
- Ceiling mounted — no need to reinforce side walls
- Boosts capacity by up to 30% with the freedom to adjust shelves to the height of the product being stored
- No posts on the floor make cleaning easy
- Shelves can be removed without tools for cleaning
- Easy and fast adjustment of shelves; simply slide the shelf sideways to lift out of current location
- Antimicrobial grey epoxy coating for maximum cleanliness and moisture resistance



## Mod-A-Flex® Shelves

Model No.	W x L		Weight	
	(In)	(mm)	(Lbs.)	(Kg)
MX1824GR	18 x 22.5	451 x 572	9	4
MX1836GR	18 x 34.5	451 x 876	12	5
MX1848GR	18 x 46.5	451 x 1181	15	7
MX2124GR	21 x 22.5	527 x 572	12	5
MX2136GR	21 x 34.5	527 x 876	17	8
MX2148GR	21 x 46.5	527 x 1181	21	9.5

Mod-A-Flex® Shelves are available:  
 In 11-3/4", 17-3/4" and 20-3/4" widths  
 In 22-1/2", 28-1/2", 34-1/2", 40-1/2" and 46-1/2" lengths  
 Nominal shelf widths are: 12", 18" and 21"  
 Nominal shelf lengths are: 24", 30", 36", 42" and 48"  
 NOTE: Two support arms included with each shelf



## Mod-A-Flex® Standards For Cooler Freezer

Model No.	Height		Weight	
	(In)	(mm)	(Lbs.)	(Kg)
MX68GR	68	1727	9	4
MX72GR	72	1829	12	5
MX81GR	81	2057	15	6

## Mod-A-Flex® Standards For Dry Environments

Model No.	Height		Weight	
	(In)	(mm)	(Lbs.)	(Kg)
MXD72GR	72	1829	11	5
MXD85GR	85	2159	13	6

Mod-A-Flex® Standards are available:  
 In 24", 36", 40", 61" 68", 72", 81" and 85" heights for installation in coolers and freezers  
 18", 36" and 85" for installation in dry environments  
 With Extender Kits to increase installation height

### The Mod-A-Flex® Secret

The patented secret to this postless system is that standards are securely suspended from the ceiling of the walk-in cooler. This provides the strength assurance that each shelf will support 400 lbs of static weight.

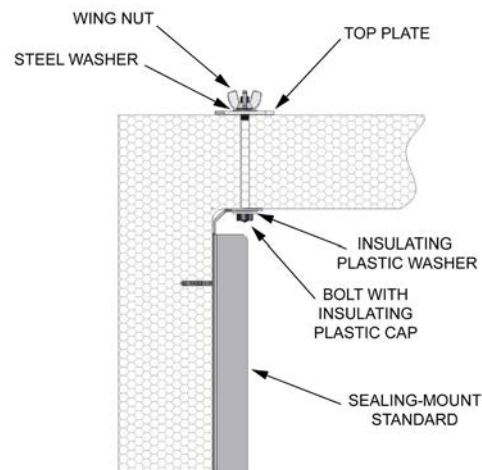

## KELMAX ADJUSTABLE Cantilever shelving

Extraordinary strength and space efficiency combined with easy stock access and exceptional corrosion resistance — they're the traits that elevate Kelmax above the competition and make our cantilever shelving the best choice for your cooler and freezer storage needs.



### Kelmax Cantilever Shelving

- Made of heavy-gauge aluminum — which is strong, durable, lightweight and never rusts
- The cantilever system is ideal for increasing usable space in coolers and freezers — since there are no front posts, storage is maximized and access is much easier
- Aluminum construction offers higher load ratings — larger loads can be supported across a longer span of shelving
- Available with a choice of channel, tubular and solid shelving
- Aluminum shelving is ideal in hot or caustic applications that might damage the coating of wire shelving



### Kelmax Cantilever Fixed Shelving Units

- Includes frame and 2 – 4 fixed shelves (20" or 24" depths)
- For safety, front legs do not extend past the bottom shelf
- Tubular bottom shelf is standard with all kits, and is easily removed without the use of tools for cleaning — all other shelves are fixed and not adjustable or removable
- Clearance between fixed shelves:
  - Two-shelf unit: 59"
  - Three-shelf unit: 28"
  - Four-shelf unit: 18"
- Channel and tubular shelves support 1500 lbs. per shelf — solid shelves support 900 lbs. per shelf
- Freestanding unit — does not require bolting to walls for support

### Kelmax 4-Shelf Units

Channel Shelf Model No.	Tubular Shelf Model No.	Solid Shelf Model No.	L x W x H		Weight	
			(in.)	(mm)	(Lbs.)	(Kg)
<b>20-in. Wide Shelves</b>						
4H0310	4H0370	4H0399	36 x 20 x 72	914 x 508 x 1829	68	31
4H0341	4H0381	4H0408	48 x 20 x 72	1219 x 508 x 1829	84	38
4H0362	4H0388	4H0413	60 x 20 x 72	1524 x 508 x 1829	97	44
<b>24-in. Wide Shelves</b>						
4H0317	4H0378	4H0403	36 x 24 x 72	914 x 610 x 1829	72	33
4H0351	4H0386	4H0411	48 x 24 x 72	1219 x 610 x 1829	92	41
4H0366	4H0395	4H0416	60 x 24 x 72	1524 x 610 x 1829	106	48

Also available in 2-tier and 3-tier units

## Kelmax Cantilever Frames and Adjustable Shelves

- Tubular base dunnage shelf is standard, and easily removed without the use of tools for cleaning
- Up to 5 additional shelf positions — shelves can be added or removed without tools
- Available in two shelf depths: 20" and 24"
- Clearance between adjustable shelves is 10"
- Maximum load capacity per shelving unit is 2,800 lbs
- Frames and adjustable shelves sold separately

## Kelmax Cantilever Frames

Model No.	L x W x H (in.)	L x W x H (mm)	Weight (Lbs.) (Kg)	
<b>20-In Deep Shelving Frame</b>				
4H4201	36 x 20 x 72	914 x 508 x 1829	49	22
4H4366	48 x 20 x 72	1219 x 508 x 1829	55	25
4H4482	60 x 20 x 72	1524 x 508 x 1829	61	27
<b>24-In Deep Shelving Frame</b>				
4H4501	36 x 24 x 72	914 x 610 x 1829	64	29
4H2977	48 x 24 x 72	1219 x 610 x 1829	75	31
4H4500	60 x 24 x 72	1524 x 610 x 1829	86	39



## Kelmax Cantilever Shelves

Channel Shelf Model No.	Tubular Shelf Model No.	Solid Shelf Model No.	L x W (in.) (mm)		Weight (Lbs.) (Kg)	
<b>20-in. Deep Shelves</b>						
4H4202	4H4203	4H4450	36 x 20	914 x 508	10	4
4H4368	4H4439	4H4561	48 x 20	1219 x 508	12	5
4H5129	4H4568	4H4484	60 x 20	1524 x 508	14	6
<b>24-in. Deep Shelves</b>						
4H4713	4H4505	4H5132	36 x 24	914 x 610	11	5
4H2978	4H2979	4H4938	48 x 24	1219 x 610	13	6
4H4763	4H4504	4H5473	60 x 24	1524 x 610	15	7



SPG's foodservice products are all manufactured to meet NSF standards. For specific items, visit [www.nsf.org](http://www.nsf.org)

## Kelmax Tubular Base Dunnage Shelf

Model No.	L x W (In.) (mm)		Weight (Lbs.) (Kg)	
<b>20-Inch Deep Shelves</b>				
4H4400	36 x 20	914 x 508	10	4
4H4367	48 x 20	1219 x 508	12	5
4H4483	60 x 20	1524 x 508	14	6
<b>24-Inch Deep Shelves</b>				
4H4509	36 x 24	914 x 610	11	5
4H4432	48 x 24	1219 x 610	13	6
4H4508	60 x 24	1524 x 610	15	7

## How To Order

1. Choose frame size
2. Choose tubular base dunnage shelf that matches the frame size
3. Choose type of shelf (channel, tubular or solid) and the shelf size
4. Specify the number of shelves